



STATIC LOAD



120
kN

DYNAMIC LOAD



60
kN

TORQUE at 25MPa



2900
Nm

WEIGHT



64
kg

OILFLOW



35
l/min

DOUBLE BEARING

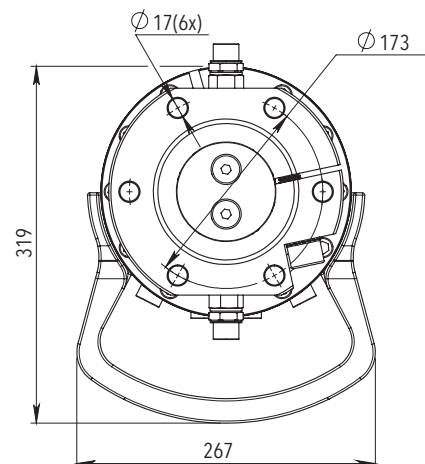
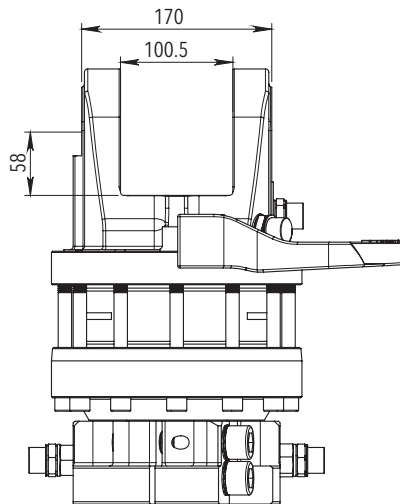
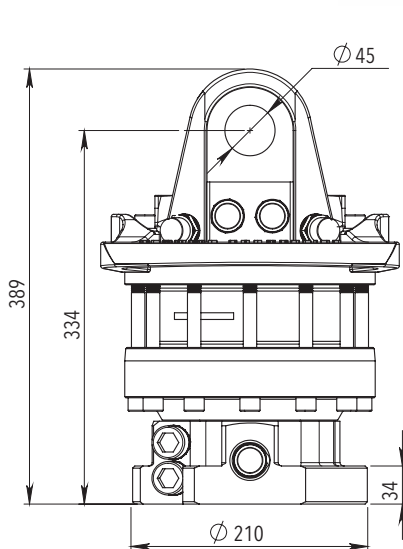

For additional information relating to price levels and technical data, please contact sales@formiko.lv

Formiko Hydraulics Ltd
Dzirciema Str. 119 k-1
Riga LV1055
LATVIA

+371 294 49 552
+371 264 59 383
sales@formiko.lv
www.formiko.lv

Formiko Hydraulics FHR 12 rotators are developed for heavy duty machinery to meet the highest demands for quality and reliability.



FORESTRY



AGRICULTURE



CONSTRUCTION



GENERAL CARGO



RECYCLING

