



STATIC LOAD



60
kN

DYNAMIC LOAD



30
kN

TORQUE at 25MPa



1850
Nm

WEIGHT



48
kg

OILFLOW



25
l/min

COMPATIBILITY



FHL02



DOUBLE BEARING

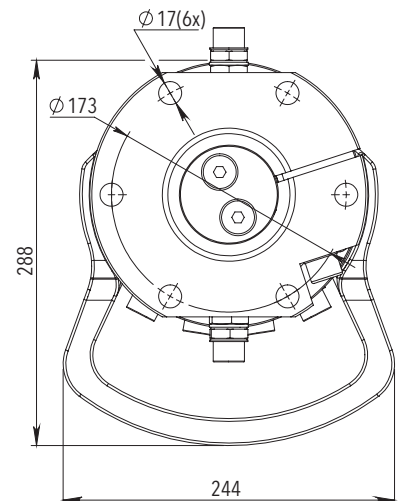
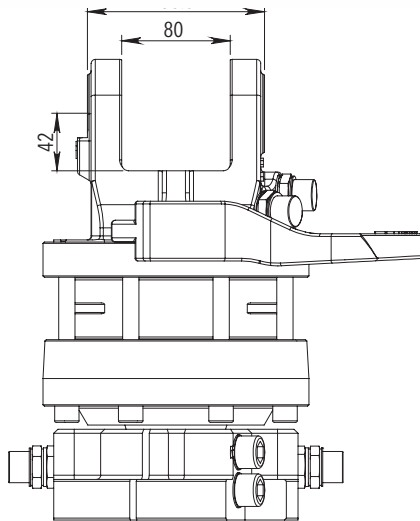
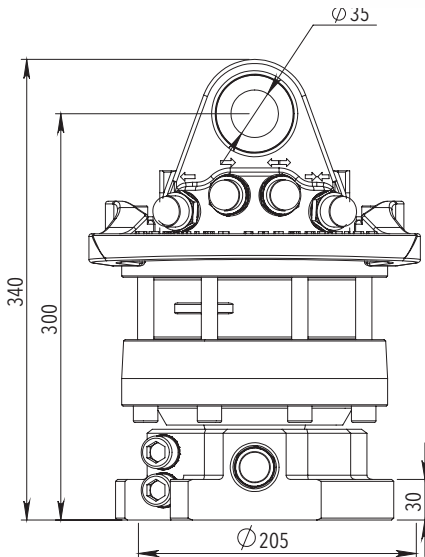
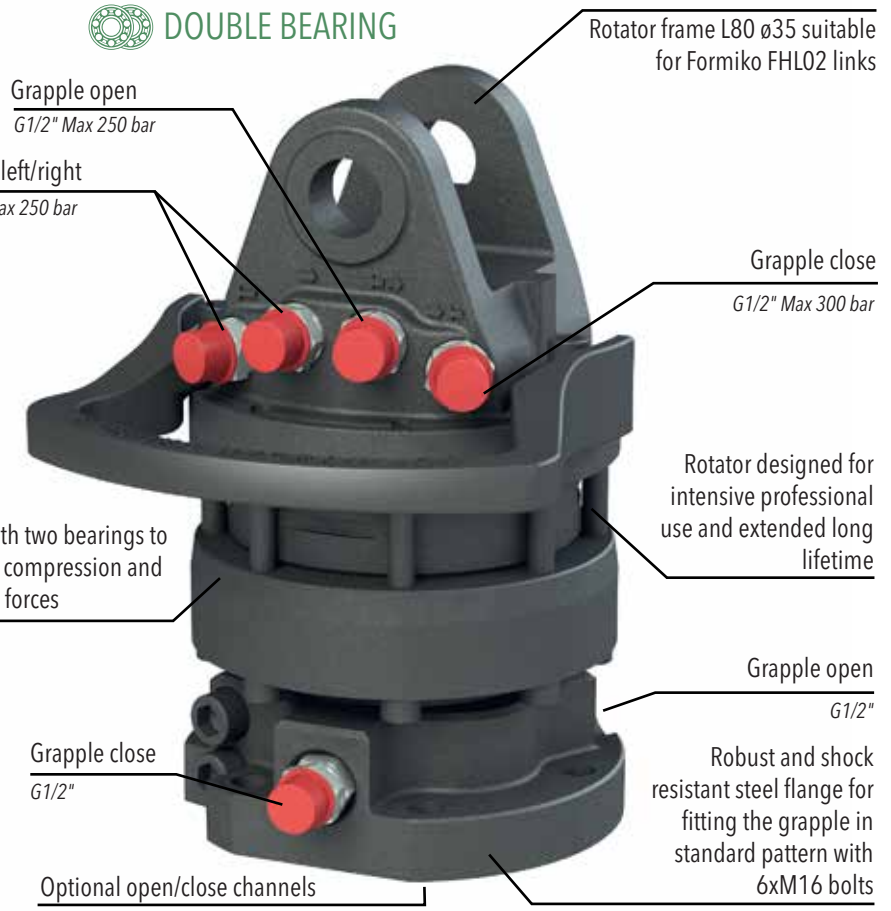

For additional information relating to price levels and technical data, please contact sales@formiko.lv

Formiko Hydraulics Ltd
Dzirciema Str. 119 k-1
Riga LV1055
LATVIA

+371 294 49 552
+371 264 59 383
sales@formiko.lv
www.formiko.lv

Formiko Hydraulics FHR 6 rotators are ideal for professional forestry and general cargo handling.



FORESTRY



AGRICULTURE



CONSTRUCTION



GENERAL CARGO



RECYCLING

