



STATIC LOAD



60
kN

DYNAMIC LOAD



30
kN

TORQUE at 25MPa



1850
Nm

WEIGHT



51
kg

OILFLOW



25
l/min

COMPATIBILITY



FHL02

← OPPOSITE HOSE CONNECTION



DOUBLE BEARING

Rotator frame L80 ø35
suitable for Formiko
FHL02 links

Rotate left/right
G1/2" Max 250 bar

Grapple close
G1/2" Max 300 bar

Grapple open
G1/2" Max 250 bar

Rotator with two bearings
to withstand compression
and stretching forces

Rotator designed for
intensive professional
use and extended long
lifetime

Grapple close
G1/2"

Grapple open
G1/2"

Robust and shock resistant
steel flange for fitting the
grapple in standard
pattern with 6xM16 bolts

Optional open/close channels

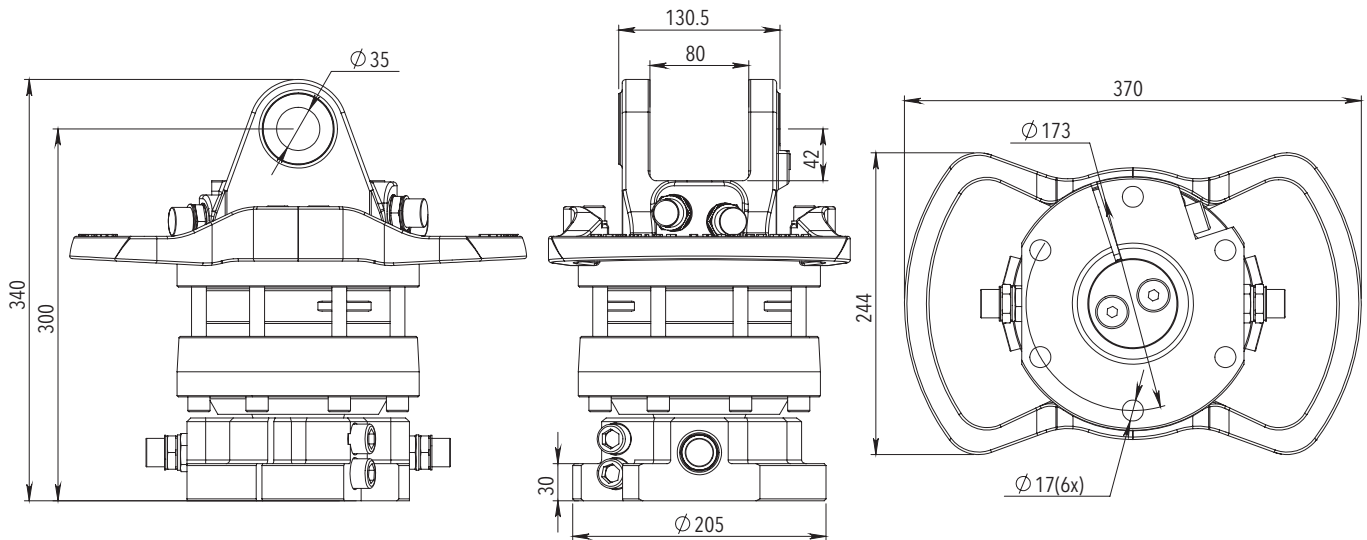

For additional information relating to price levels and technical data, please contact sales@formiko.lv

Formiko Hydraulics Ltd
Dzirciema Str. 119 k-1
Rīga LV1055
LATVIA

+371 294 49 552
+371 264 59 383
sales@formiko.lv
www.formiko.lv

Formiko Hydraulics FHR 6 rotators are ideal for professional forestry and general cargo handling.



FORESTRY



AGRICULTURE



CONSTRUCTION



GENERAL CARGO



RECYCLING

