



STATIC LOAD



60
kN

DYNAMIC LOAD



30
kN

TORQUE at 25MPa



1850
Nm

WEIGHT



40
kg

OILFLOW



25
l/min

COMPATIBILITY



FHL02



DOUBLE BEARING

Grapple open
G1/2" Max 250 bar

Rotate left/right
G1/2" Max 250 bar

Rotator with two bearings
to withstand compression
and stretching forces

Rotator frame L80 ø35 suitable
for Formiko FHL02 links

Grapple close
G1/2" Max 300 bar

Rotator designed for
intensive professional
use and extended
long lifetime

Grapple close
G1/2"

Grapple open
G1/2"

Tough steel shaft with increased
diameter for fitting the grapple

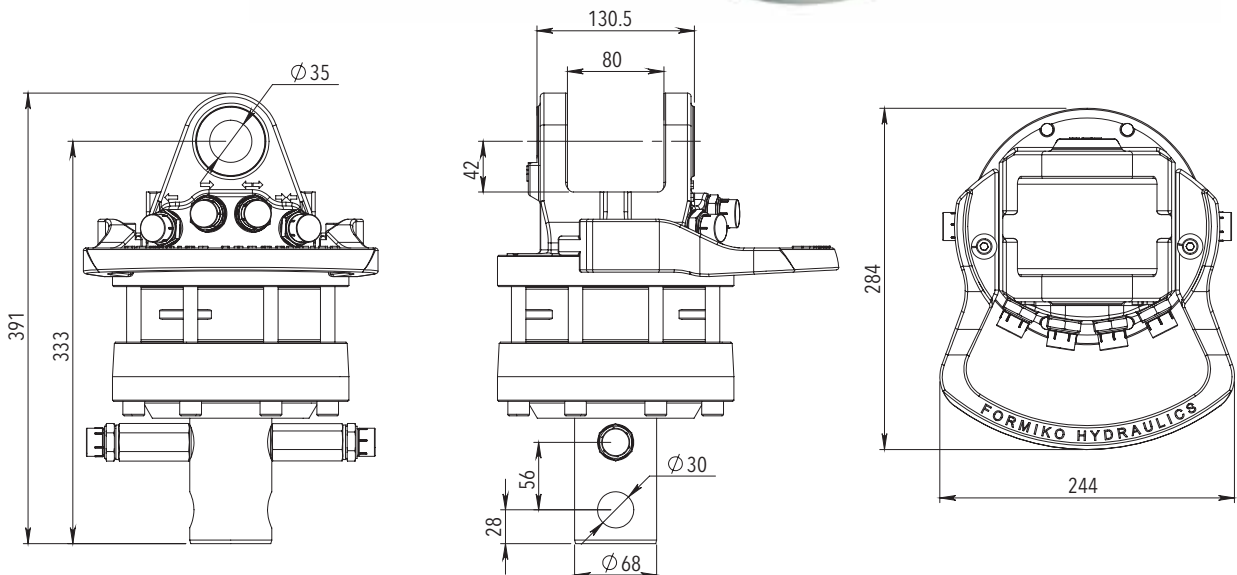

For additional information relating to price levels and technical data, please contact sales@formiko.lv

Formiko Hydraulics Ltd
Dzirciema Str. 119 k-1
Rīga LV1055
LATVIA

+371 294 49 552
+371 264 59 383
sales@formiko.lv
www.formiko.lv

Formiko Hydraulics FHR 6 rotators are ideal for professional forestry and general cargo handling.



FORESTRY



AGRICULTURE



CONSTRUCTION



GENERAL CARGO



RECYCLING

