

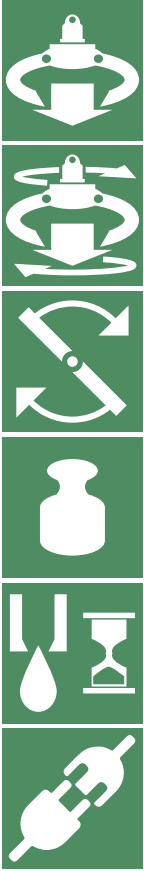

STATIC LOAD  
DYNAMIC LOAD  
TORQUE at 25MPa  
WEIGHT  
OILFLOW  
COMPATIBILITY



**60**  
kN

**30**  
kN

**1850**  
Nm

**40**  
kg

**25**  
l/min



FHL02

**DOUBLE BEARING**

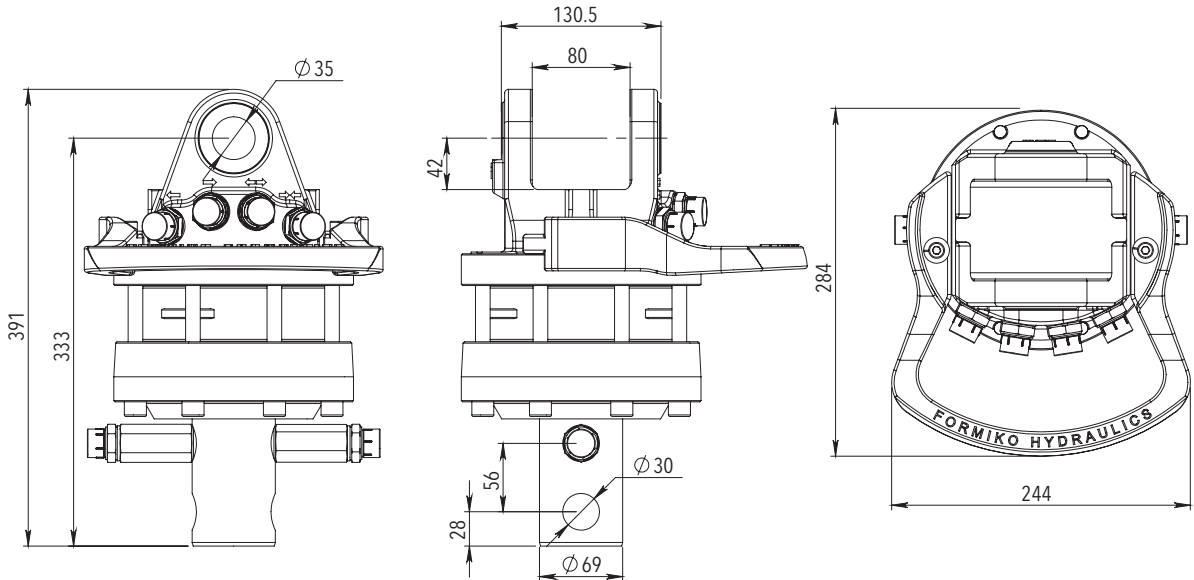
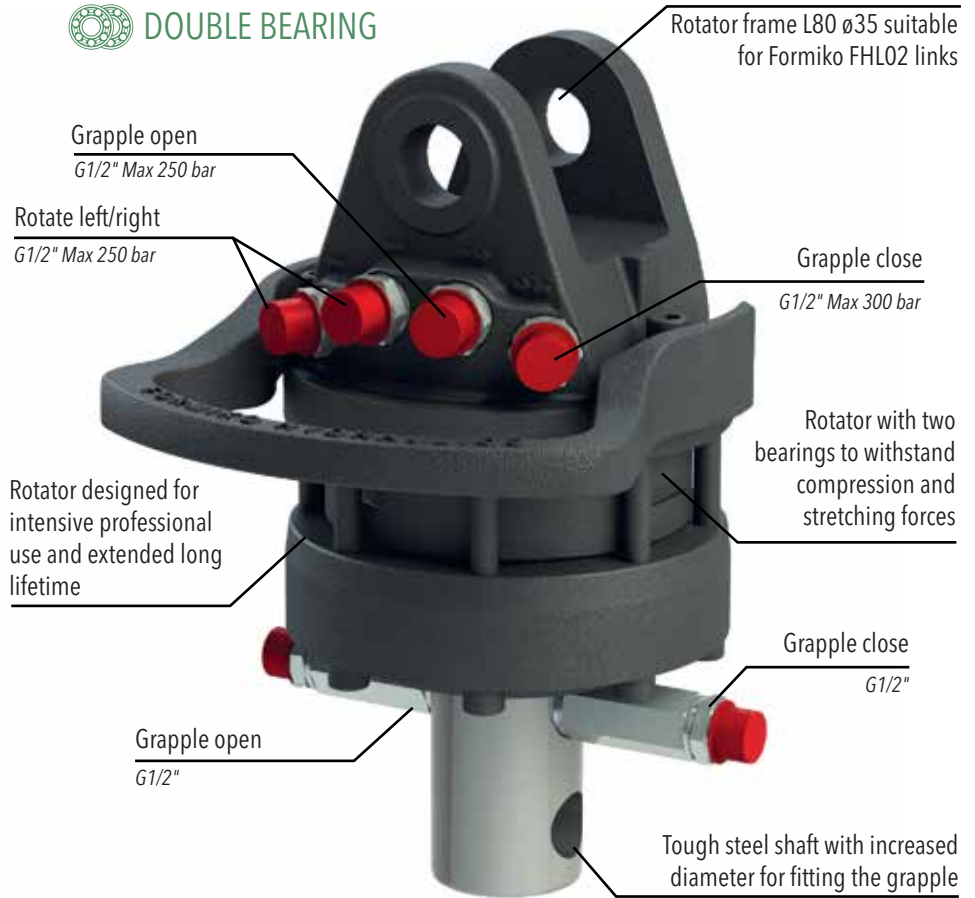

For additional information relating to price levels and technical data, please contact [sales@formiko.lv](mailto:sales@formiko.lv)

Formiko Hydraulics Ltd  
Dzirciema Str. 119 k-1  
Riga LV1055  
LATVIA

+371 294 49 552  
+371 264 59 383  
[sales@formiko.lv](mailto:sales@formiko.lv)  
[www.formiko.lv](http://www.formiko.lv)

Formiko Hydraulics FHR 6 rotators are ideal for professional forestry and general cargo handling.



FORESTRY



AGRICULTURE



CONSTRUCTION



GENERAL CARGO



RECYCLING

