



STATIC LOAD



**60**  
kN

DYNAMIC LOAD



**30**  
kN

TORQUE at 25MPa



**1850**  
Nm

WEIGHT



**43**  
kg

OILFLOW



**25**  
l/min

COMPATIBILITY



FHL02



DOUBLE BEARING

OPPOSITE HOSE CONNECTION

Grapple close  
G1/2" Max 300 bar

Grapple open  
G1/2" Max 250 bar

Rotator with two bearings to withstand compression and stretching forces

Grapple open  
G1/2"

Rotator frame L80 ø35 suitable for Formiko FHL02 links

Rotate left/right  
G1/2" Max 250 bar

Rotator designed for intensive professional use and extended long lifetime

Grapple close  
G1/2"

Tough steel shaft with increased diameter for fitting the grapple

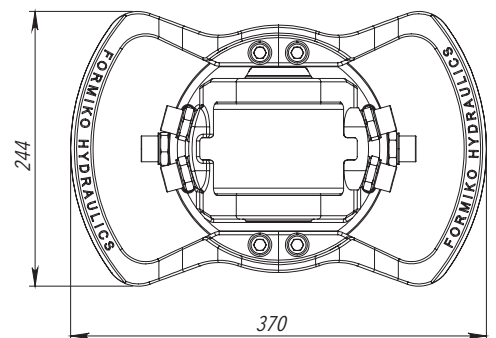
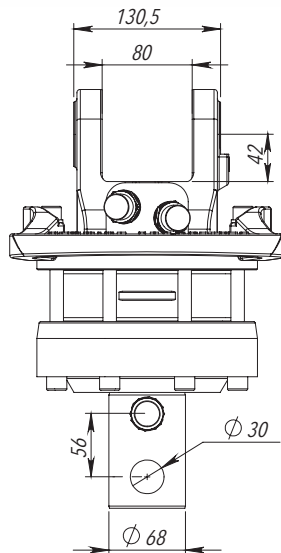
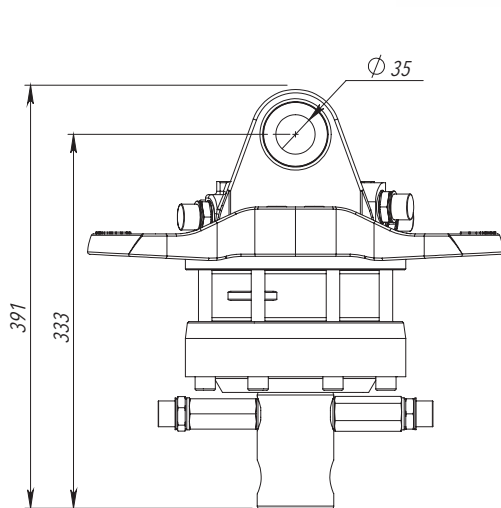

For additional information relating to price levels and technical data, please contact [sales@formiko.lv](mailto:sales@formiko.lv)

Formiko Hydraulics Ltd  
Dzirciema Str. 119 k-1  
Rīga LV1055  
LATVIA

+371 294 49 552  
+371 264 59 383  
[sales@formiko.lv](mailto:sales@formiko.lv)  
[www.formiko.lv](http://www.formiko.lv)

Formiko Hydraulics FHR 6 rotators are ideal for professional forestry and general cargo handling.



FORESTRY



AGRICULTURE



CONSTRUCTION



GENERAL CARGO



RECYCLING

